

ALTMAN

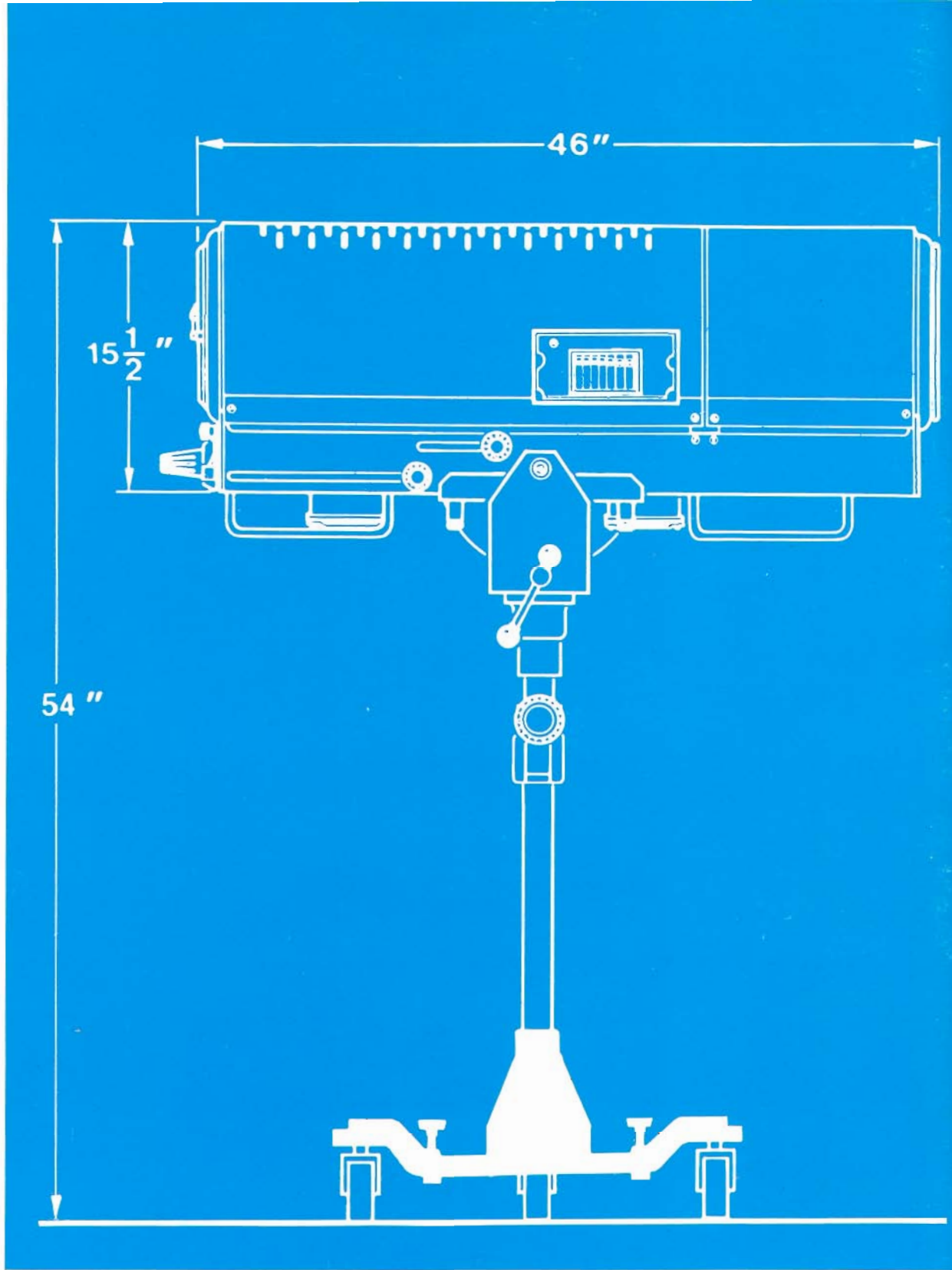

Follow Spots

THE QUALITY OF LIGHT
Altman Stage Lighting Company, Inc., 57 Alexander Street, Yonkers, NY 10701 • 914-476-7987 or 212-569-7777. FAX: 914-963-7304

This catalog supplement has been created to allow the lighting designer to compare and specify follow spots in a concise and easy to understand manner. Altman Stage Lighting Co., Inc. has been servicing our industry by designing and manufacturing quality stage lighting equipment for over forty years, and will continue that same tradition for many more years to come.

All products listed in this supplement are stock items and are available for immediate shipment. Full specifications on all products are available from Altman Stage Lighting or any authorized Altman dealer. All units can be relamped without use of tools, and operate on a standard 15 amp, 120VAC receptacle. Except for the 902, 902 Jr., Dyna Spot, and 1000Q, all fixtures are provided with a lamp. Trouping cases are available for all units, and most follow spots are available for use with different voltages and frequencies. Consult the factory for details concerning these options.

Osrarn, HTI, and HMI are registered trademarks of Osrarn GmbH, Germany.
Irem is a registered trademark of IREM SPA, Italy.



902

902 JR.

The 902, 902 Jr., and Dyna Spot family of follow spots are rugged, moderately priced units that incorporate all the features of the higher priced models. Each luminaire comes equipped with rear operated iris, shutter, and focus adjustments. The 902 and the Dyna Spot also include a 6-color boomerang with douser. The 902 Jr. has a front mounted color frame holder that accepts standard 7 1/2" x 7 1/2" frames. The stands provided are fully adjustable and have positive-locking pan and tilt mechanisms. The 902 and the Dyna Spot stands are casters. All units are equipped with a cable hanger and an integral 25 foot power cable, and are listed by Underwriters Laboratories for 1500 watts. Each fixture also comes with a power-on/off switch for added convenience. The 902 and 902 Jr. are convection cooled and are ideal for small theatres, clubs, churches, and schools where a maximum 60 foot throw is required. The Dyna Spot is equipped with a low-noise blower and is perfect for similar locations where a maximum throw of 100 feet is necessary.

DYNA SPOT



1000 Q

The 1000Q is the luminaire that set the standard for all small-house follow spots. With rear mounted controls and a fully adjustable castered stand, this Underwriters Laboratories listed unit is well suited for high school and college auditoriums, small theatres, and cabarets. This fixture utilizes a highly efficient 1000 watt tungsten-halogen quartz lamp for a uniformly brilliant and powerful beam spread. Integral iris and shutter are included, as well as a 6-color boomerang with douser. Also included is an on/off switch for the power as well as a 25 foot power cable and a cable hanger. Ideal for throws from 25 feet up to 125 feet, the affordable, full-featured 1000Q follow spot has no equal.

ALTMAN

THE QUALITY OF LIGHT

COMET

The Comet is a very durable medium to long throw follow spot that incorporates the unmatched light quality and efficiency of the tungsten-halogen MR-16 family of lamps. It uses the high performance 360 watt FLE or ENX lamp for low power consumption, but delivers a highly intense beam for throws up to 150 feet. The unit comes complete with top operated iris, shutter, and dimmer controls, as well as a self-canceling 6-color boomerang with douser. A removable 25 foot power cord and fully adjustable castered stand are included. Dual adjustable lenses for optimum beam control make the Comet a perfect luminaire for high school and college auditoriums, cabarets, and small theatres.

SATELLITE I

With a 7° to 20° zoom range, the Satellite I is one of the most adaptable followspots available. The iris can also alter the beam to achieve a 4.7 foot diameter spot at 150 feet, making this a truly versatile unit. This follow spot uses an Osram 575 watt HMI lamp, and comes complete with dual lens adjustments, rear operated iris, dimmer and shutter controls, and a self-canceling 6-color boomerang with douser. The power supply and a 10 foot power cable are also included. The fully adjustable castered stand is easily disassembled for trouping. The Satellite I is great for colleges, theatres, small concerts, and low level video shoots.

VOYAGER

The Voyager is a long throw unit designed for use with the Osram 400 watt HTI lamp. The ball bearing slide assembly assures easy operation of the zoom focus feature for spot to flood adjustment. The separate fine focus control guarantees a clean, hylation-free beam edge. This unit features a self contained regulated power supply, self-canceling 6-color boomerang with douser, and top operated iris, dimmer and shutter controls. The easily disassembled trouping stand is provided with casters and leveling jacks. With a 200 foot throw, the Voyager is well suited for colleges, concert and video lighting, as well as all professional stage and theatrical lighting applications.

SHORT THROW VOYAGER

The Short Throw Voyager is a compact, lightweight follow spot ideal for use on truss and lighting bridges where intense lighting is required for short to medium throw distances. Like the Voyager, this fixture utilizes the Osram 400 watt HTI lamp for its brilliance and low power consumption. The focusing lever uses a ball bearing slide assembly which makes one-handed lens adjustments quick and easy. A self-canceling 6-color boomerang with douser is included, as well as an iris, dimmer and shutter. The luminaire also comes with an internal regulated power supply and an easily disassembled trouping stand complete with casters and leveling jacks.

LONG THROW EXPLORER



The Long Throw Explorer is the finest long throw follow spot in its class. With a throw of up to 500 feet, this unit is perfect for multi-purpose arenas and all professional concert, theatre, and stage applications. Its 1200 watt HMI light source by Osram also makes the Explorer ideal for TV and video shoots. A ball bearing slide assembly with adjustable drag assures easy focusing from spot to flood, and a separate fine focus control guarantees a clean, hazy-free beam edge. This follow spot includes top operated iris, dimmer, and shutter controls and a self-canceling 6-color boomerang with douser. The castored trouping stand incorporates leveling jacks and a screw-feed lift, making it truly easy to set up and operate. A detachable 12½ foot power cord and a lightweight low-noise ballast manufactured by IREM complete the package. With a light output comparable to a 2K xenon unit, which requires 35 amp fusing at 220VAC, the Explorer can be used in a standard 15 amp, 120VAC household receptacle for added convenience.

MEDIUM THROW EXPLORER

Except for a different and unique optical system, the Medium Throw Explorer has every one of the features incorporated into the Long Throw Explorer. This follow spot delivers a beam of light with a precise, even field that is absolutely perfect for ballet, TV and video, or any application where such a flawless, uniform field is required. This luminaire has a throw distance of up to 200 feet which makes this a truly remarkable unit. Like the Long Throw Explorer, this unit also uses the Osram 1200 watt HMI lamp and a lightweight low-noise ballast manufactured by IREM with a detachable 12½ foot power cable.



SHORT THROW EXPLORER

The Short Throw Explorer is the finest follow spot of its type, embodying all of the features needed for truss and lightbridge downspot applications. This nimble, well balanced unit is perfect for stages and theatres everywhere. It boasts a 6-color self-canceling boomerang with douser, a rear controlled iris and shutter, and a front and rear operated dimmer. Special features include a slot for fixed and rotating pattern holders, a standard 10" x 10" color frame/accessory holder, and a 120VAC convenience receptacle. The luminaire uses the Osram 1200 watt HMI lamp for its intensity, brilliance and low power consumption. The Short Throw Explorer also comes with a detachable 12½ foot power cord and a lightweight low-noise IREM ballast. The castored stand is provided with leveling jacks and is easily disassembled for trouping.

DISTANCE IN FEET				20	40	60	80	100	125	150	200	300	
FIXTURE	LAMP	FOCUS	FIELD ANGLE	PEAK FOOTCANDLES									CANDLE-POWER (X 1000)
				MAXIMUM DIAMETER IN FEET									
902 JR.	1500W DTJ	SPOT	33.0°	135	34	15							36
		FLOOD	46.0°	11.8	23.7	35.5							
902	1500W DTJ	SPOT	33.0°	85	21	9							54
		FLOOD	46.0°	15.6	31.3	46.9							
DYNA SPOT	1500W DTJ	SPOT	18.5°	90	23	10							138
		FLOOD	23.0°	11.8	23.7	35.5							
1000 Q	1000W FEL	SPOT	10.0°	50	13	6							412
		FLOOD	14.0°	15.6	31.3	46.9							
COMET	360W FLE	SPOT	7.2°	344	86	38	22	14					800
		FLOOD	12.2°	6.5	13.0	19.5	26.0	32.5					
SATELLITE I	575W HMI	SPOT	7.3°	258	65	29	16	10					2,400
		FLOOD	20.0°	8.2	16.3	24.4	32.6	40.7					
SHORT THROW VOYAGER	400W HTI	SPOT	1.8°	1030	258	114	64	41	26				2,500
		FLOOD	17.5°	3.5	7.0	10.5	14.0	17.5	21.9				
VOYAGER	400W HTI	SPOT	0.5°	538	134	60	34	22	14				8,500
		FLOOD	9.5°	5.0	10.0	15.0	20.0	25.0	30.7				
SHORT THROW EXPLORER	1200W HMI	SPOT	1.5°	500	222	125	80	51	36				550
		FLOOD	17.5°	6000	667	375	240	154	107				
MEDIUM THROW EXPLORER	1200W HMI	SPOT	2.5°	5.1	7.7	10.2	12.8	16.0	19.2				1,170
		FLOOD	5.5°	332	148	83	53	34	24				
EXPLORER	1200W HMI	SPOT	5.7°	14.1	21.2	28.2	35.3	44.1	52.9				7,500
		FLOOD	7.0°	6250	1563	694	391	250	160	111			

Contact Altman Stage Lighting Company Inc. for full specifications on above products. Specifications subject to change without notice. © ALTMAN STAGE LIGHTING CO., INC. 1991



Three generations of continuous pursuit of excellence.

What's in a name? Everything when its **ALTMAN**

Altman is a tradition. A family business when it started, and a family business today. Charles Altman, the patriarch, and a driving force. Robert Altman, a son, boldly leading the company into tomorrow. Randall Altman, a grandson, stride by stride with Robert striving for family pride in excellence. Ronald Altman, whose memory, still inspiring loyalty, will always live on. All give the Altman name stature and importance in the world of theatrical lighting.

Altman is dedication. Dedication to building it right, to building it in the U.S.A. Shortcuts don't exist. Only pride which shines as brightly as an Altman light itself. Pride evidenced by hands-on management And pride in lights as old as the company. . . still in service, still trouble-free.

Altman is design innovation. And technological breakthrough. It's R&D. With lighting designers schooled in optics and engineering. It's a state of the art CAD/CAM pilot production installation. So ideas can move from paper to production almost overnight.

Altman is experience. From Broadway to summer stock, the World's Fair to Woodstock, the Statue of Liberty celebration to Presidential Inaugurations, Altman is behind the scenes with innovative new pro-

ducts - a major lighting presence and the standard by which others are judged.

But first, last, and always, Altman is customer satisfaction. As the company moves steadily forward into the '90s, procedures and techniques will be incorporated to improve customer service. Customer hotlines. Faster service. Greater attention to requests for information. Computer tracking. Some have already been implemented, and more will follow. One thing is sure. Altman built its business on personal service. And this will never change.

Tradition. Dedication. Design innovation. Experience. Service. Altman is all of these. Because **Altman is the quality of light.**

Altman operates out of a modern 100,000 sq. foot facility located on the banks of the Hudson River only 8 miles north of Manhattan.



Electro-static spraying produces smooth even quality.



Efficient production, producing high quality...high volume output.



Inspected and packed with care for damage free shipment.



Well stocked hi-tech rental department.



From design to production Altman's state-of-the-art equipment assures you of the finest products.

An authorized Altman dealer:

Printed in U.S.A.

11/91 - 5M